

Strip the cable and comb out the screening braid.

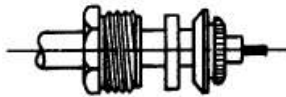

Then slide the pressure screw, gasket and clamping ring onto the cable (clamping ring only till cable sheath) and bend back the screening braid over the clamping ring. Temporary tin plating the inner conductor.

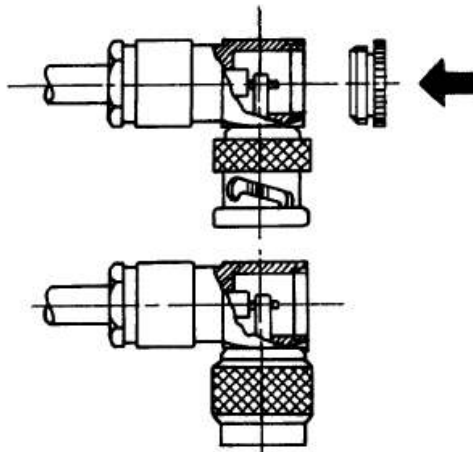

Insert the cable as far as possible in the plug connection and tighten the pressure screw.

Tin plating the inner conductor with the contact pin.

Remove excess solder. Tightly screw the locking screw.

*for Series BNC 75 Ohm Standard, BNC 50 Ohm, BNC HD eco, BNC HD, TNC 75 Ohm, TNC 50 Ohm

Assembly Instruction 3	a	b	c
Inner conductor - solder connection	10.5	4.0	3.0
Outer conductor - clamp connection			